



# Linear Motion Solutions by Thomson

Trusted Provider of Optimized Motion Solutions for 75+ Years

# Thomson – Your Trusted Partner

From precision linear motion solutions to fully integrated actuation systems, Thomson delivers intelligent, clean and efficient motion to help customers compete and scale. Whether your application demands speed, load capacity, controllability, compact design or long-term reliability, we help you design the right solution, not just the right part.

Engage with our engineering teams early to reduce design cycles, improve system integration and maximize long-term value. Product and application information, 3D models, sizing and selection tools, and global contact information are available at [thomsonlinear.com](http://thomsonlinear.com)

 **RegalRexnord**<sup>™</sup>

As a leading brand of Regal Rexnord, Thomson uniquely connects linear and actuation solutions with motors, controls, power transmission and drive technologies for enabling smarter integration, expanded design flexibility and enterprise-level support worldwide. Together with Regal Rexnord's 30,000 associates around the world, we help create a better tomorrow with sustainable solutions that power, transmit and control motion.



## Linear Ball Bushing® Bearings

Thomson invented the Linear Ball Bushing bearing more than 75 years ago and continues to be the recognized leader in this field. Offering the widest range of bearings and accessories, we easily satisfy the broadest set of requirements with the best performing product for the application.

- Most extensive and premium product offering in the industry with leading dynamic load capacity density and true, self-aligning functionality
- Pre-assembled, ready-to-install bearings provide low friction and smooth, accurate motion
- Cutting-edge segmented technology
- Specialized product options for common application needs such as increased corrosion resistance, debris tolerance and lubrication retention
- When used with Thomson 60 Case shafting, our linear bearings last up to 50% longer than conventional models



## 60 Case® LinearRace® Shafting

Thomson shafting is manufactured to the highest quality standards in an ISO 9001:2015 registered facility to provide industry leading hardness, surface finish, roundness, straightness and cylindricity.

### 60 Case LinearRace Shafting

- Premium 1566 steel and industry leading case depth as standard
- The inner race for Thomson Ball Bushing bearings extends life as much as 50% over the competition
- Available with multiple industry preferred material and coating options
- Common value-added machining options can be configured and ordered directly on the Thomson website
- Full custom machining capabilities to produce your prints at any volume
- Stocked in multiple locations globally





## Profile Rail Linear Guides

Thomson has a complete offering of rails and carriages in a broad range of styles and sizes and is a “one-stop shop” for all of your profile rail needs.

### 400 Series

- Extensive product offering featuring double-faced ball bearing design in industry standard sizes

### 500 Series

- Double-backed ball bearing and roller bearing designs provide exceptional straightness, rigidity, load capacity and accuracy

### MicroGuide® Series

- Miniature linear guides with standard and wide rail as small as 5 mm in 440C stainless steel

### T Series

- Lightweight, self-aligning rail made from aircraft-grade aluminum



## Compact Linear Systems

Thomson compact linear systems address the need for thrust and bearing support in a single, small-scale unit for space-conscious applications. Whether you opt for one of our three standard architectures or work with our engineers on a “from scratch” solution, your application requirements will determine the selection and sizing of your system components.

- Mounting blocks can be machined to virtually any shape or size
- Virtual design consultations provide expert guidance for your solution build
- Automated, back-end modularity processes allow systems to be produced and delivered quickly
- Receive a 3D model of your system in real time or within a business day

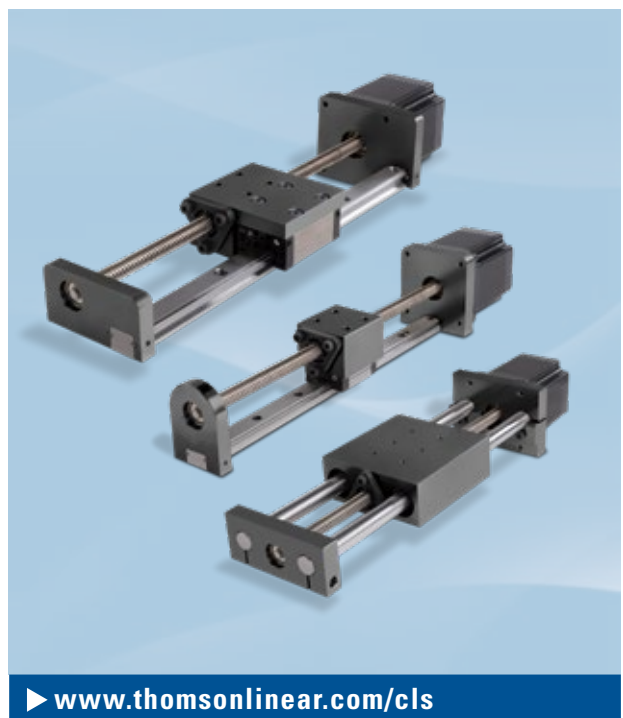

## Linear Motion Systems

Thomson invented the linear motion system and offers the largest range in the industry. These systems are ideal for handling, packaging and other factory automation applications that require high speed and/or long stroke capabilities.

- Flexibly designed, self-supporting units
- Can easily be assembled into X-Y and gantry configurations using multi-axis mounting accessories
- Sizes ranging from the smallest to the biggest in the industry
- Ball screw or belt-driven models
- Ball-, wheel- or prism-guided models
- RediMount™ motor mounting adapter kit is available as standard on all models
- Large range of options and accessories
- Sealing and washdown options are available for harsh environments

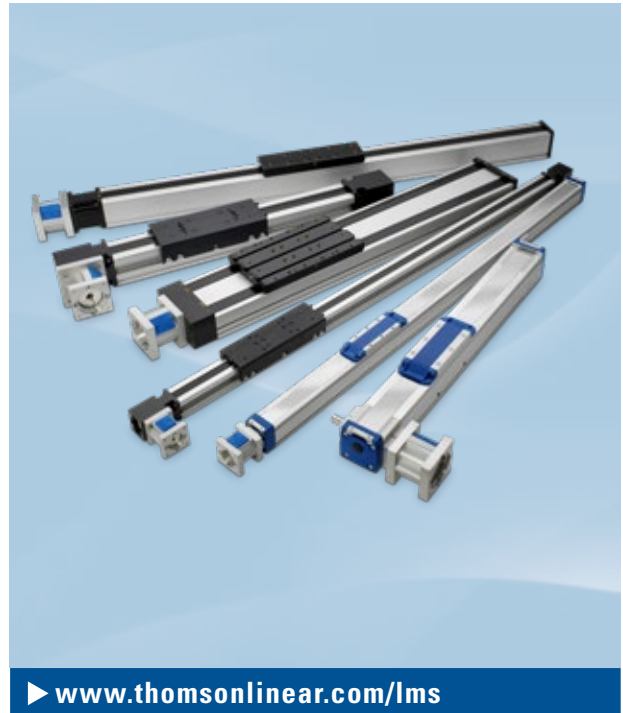

▶ [www.thomsonlinear.com/lms](http://www.thomsonlinear.com/lms)

## Worm Gear Screw Jacks

Ruggedly designed and produced with load-handling capacities up to 100 tons, Thomson screw jacks can be employed individually or easily configured into a multitude of synchronized, motorized arrangements.

### ActionJac™ Series

- USA-made with rugged design and load handling from 1/2 to 100 tons
- Built to specification
- Anti-friction, tapered roller bearings with external seals to prevent loss of lubrication

### MULI® and JUMBO® Series

- German-made, symmetrical housing allows for universal mounting from either end
- Load handling from 5 to 500 kN
- Designed for easy installation of motors, gears and shaft encoders



▶ [www.thomsonlinear.com/wgsj](http://www.thomsonlinear.com/wgsj)

## Electric Linear Actuators

Our linear actuator range is one of the broadest on the market, and we can offer a suitable model for almost any imaginable application. Thomson also has a long experience in designing custom solutions and builds more custom actuators than anyone.

### Smart Actuators

- Includes Electrak® XD, HD, MD, LL and Throttle models
- Integrated onboard electronics, including CAN bus, for advanced control options, communication and performance
- Unrivalled environmental protection (IP69K/IP67 static and IP66 dynamic)

### H-Track

- Electrohydraulic actuator that incorporates a patented fluid power design with unmatched impact resistance
- Completely sealed system with no hoses to leak



## Precision Linear Actuators

The compact design and higher load capacities of our precision linear actuators make them ideal for the replacement of hydraulic and pneumatic cylinders.

### T Series

- Robust, precise-positioning, high-load actuators
- Three sizes and a multitude of accessories available
- Mounting kits according to hydraulic standards available

### ECT Series

- Fully motorized precision linear actuators
- Choose between a large number of motor, gear box and mounting alternatives

### PC Series

- Built to replace pneumatic cylinders
- High power density, accuracy and life expectancy
- Visit [www.thomsonlinear.com/conversion](http://www.thomsonlinear.com/conversion) to learn more about the PC Series

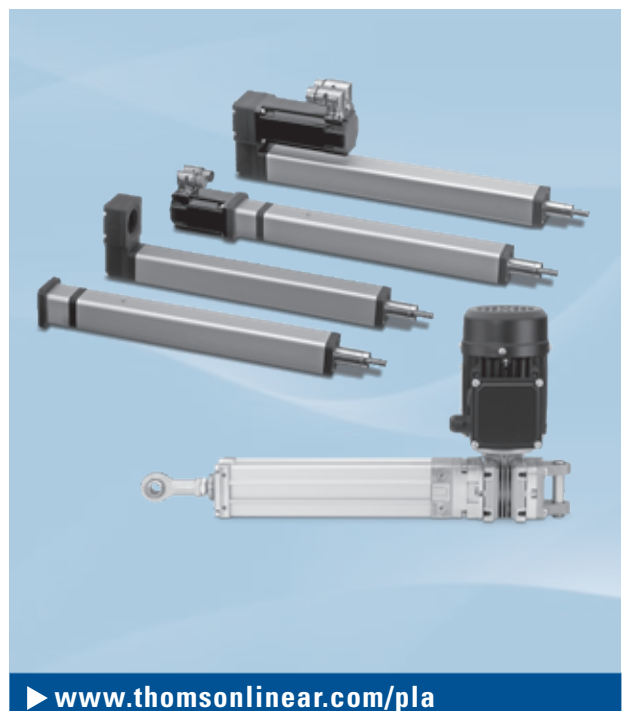

## Lifting Columns

Thomson lifting columns are ideal for medical applications such as wheelchair lifts, x-ray machines, and surgical tables as well as ergonomic automation applications such as workstations and desk lifts.

### LC2000 Series

- Three-piece extrusion with 2000 N loading capacity
- Telescoping lead screw mechanism to provide an ideal extension-to-retraction ratio

### LC3000 Series

- Three-piece extrusion with ball screw drive to allow for 3000 N loading capacity and high moment loading



► [www.thomsonlinear.com/lc](http://www.thomsonlinear.com/lc)

## Stepper Motor Linear Actuators

Stepper motor linear actuators combine a hybrid stepper motor and a precision lead screw together in one compact envelope. Patented Taper-Lock technology\* allows quick decoupling and secure, properly aligned connections. This combination offers several advantages over a traditional solution.

- Motors come in five standard NEMA frame sizes with various stack and motor winding combinations available
- Many lead screw diameters, leads, coatings and lead nut combinations available
- Achieves the highest torque density in the industry
- Taper-Lock design provides the ability to quickly decouple the lead screw from the stepper motor
- Comes in two standard configurations: rotating screw (MLS) and rotating nut (MLN)
- Custom assemblies available

\* Patent No. 9400047

[www.thomsonlinear.com](http://www.thomsonlinear.com)



► [www.thomsonlinear.com/mls](http://www.thomsonlinear.com/mls)



## Ball Screws

We offer the most complete line of industrial ball screws. Our products range from standard to high-precision assemblies, as well as custom solutions.

### High Load Series

- Handles maximum dynamic loads up to 1440 kN

### Miniature Precision Rolled Series

- Efficient, cost-effective solution in a small envelope

### Precision Rolled Series

- The most comprehensive offering of low-cost, high-precision metric and inch ball screws in the industry

### Precision Whirled/Ground Series

- High repeatability, accuracy and stiffness



## Lead Screws

Thomson offers the highest-quality, precision lead screw assemblies in the industry, providing an excellent economical solution for your linear motion requirements.

- Diameters as small as 2 mm
- Carbon alloy acme screws assembled with bronze nuts are highly effective for industrial, high-load applications
- Acme screw assemblies available standard with end bearing blocks for simple design and installation
- Lead nuts come in a standard threaded or flanged mounting configuration
- Anti-backlash nuts for the best positional repeatability
- Custom lead screw machining and lead nuts available



## Ball Splines

Thomson ball splines, which enable rotary and linear motion on a single shaft, deliver high reliability and life expectancy under varying operating conditions. Ball splines are optimal for applications that require high speed, vibration, shock loading, precise positioning requirements and high torsional loads.

- Anti-friction linear travel by ball recirculation
- Resistance to radial displacement resulting from torque loads
- Minimal lash resulting from wear and elimination of stick-slip
- Minimized friction reduces heat, preventing seizure
- Custom machined keyways are available for both inner and outer race
- Available in torque-optimized and precision radial load-optimized versions



## Glide Screws™

The Glide Screw combines the features of a linear bearing and a lead screw in one smooth operating package, thus creating something better than both. The patented Glide Screw delivers high performance, fast installation and less complexity in a small package.

- Easy and fast to install and maintenance free
- Reduced footprint, improved equipment uptime and lower cost of ownership
- Metric and inch options available
- Integrated lubrication block
- Optional configurations for harsh environments





## Miniature Systems and Components

Thomson produces the widest selection of miniature linear components that are engineered to work together. They all benefit from our long experience in motion control engineering and have all the advantages and features offered for standard-size products.

- Smaller components enable designers to reduce the size and weight of their end product, resulting in products that are smaller, lighter and less expensive to manufacture
- Widest variety of miniature motion products on the market
- Products are designed to work together
- Thomson offers easy and fast customization



## Customization and White Paper Designs

Applications often have unique challenges that cannot always be solved by an off-the-shelf solution. Thomson specializes in providing custom-engineered solutions quickly and cost effectively to address these requirements. We frequently develop and ship products that have been altered in one or several ways such as:

- Custom materials
- Custom surface treatment
- Custom size or geometry
- Custom assemblies
- Custom services
- New designs



## Online Sizing & Selection Tools and Design Resources

At Thomson, we provide world-class customer support by offering a wide variety of online application, selection and training tools. Together with our direct contact customer support center, we can help you find the product that best fits your application needs.

- Linear Motioneering - application tools for quick and easy sizing and selection
- Product Selectors - attribute-based selection tools help you search for product that best meets your application needs
- CAD Models - free configurable 2D/3D models are available to download for most of our products
- Training Site - learn more about motion control and related products by studying our vast library of content, including graphics, videos and webinar recordings

► [www.thomsonlinear.com/en/design-tools](http://www.thomsonlinear.com/en/design-tools)



## Innovation, Engineering and Customization Excellence

Often the ideal design solution is not about finding the fastest, sturdiest, most accurate or even the least expensive option. Rather, the ideal solution is the optimal balance of performance, life and cost.

Thomson continues to innovate, both in products and tools necessary for design engineers to select, size and specify the optimal component for any application – regardless of industry or market. From standard products to “white sheet” designs, Thomson has the engineering expertise and manufacturing capabilities to optimize the balance between performance and cost to suit your specific needs. Our engineered, custom designs, as well as our multitude of free, online tools, set us apart from other manufacturers and create a benchmark in the linear motion industry.



► [www.thomsonlinear.com/materialhandling](http://www.thomsonlinear.com/materialhandling)

### Material Handling

Improve speed, accuracy and reliability by using the broad range of Thomson products in AGVs, logistics trains, forklifts and pick-and-place equipment.



► [www.thomsonlinear.com/medical](http://www.thomsonlinear.com/medical)

### Medical and Health

Both patients and caregivers will benefit from easier-to-use, safer, lighter, smaller and more precise machines made possible by Thomson products.



► [www.thomsonlinear.com/a&d](http://www.thomsonlinear.com/a&d)

### Aerospace and Defense

Our expertise in linear motion technology has lent itself to countless high-level applications in commercial and military aircraft, ground defense and weapons systems.



► [www.thomsonlinear.com/machinetools](http://www.thomsonlinear.com/machinetools)

### Machine Tools

Thomson has supplied high-performance lead screws and linear guides to machine tool manufacturers for decades.

## Decades of Application Expertise

Since the company was founded, Thomson has been one of the forerunners in the motion technology industry. Our inventions and products have been supplying optimized motion solutions to a broad range of companies and application areas.

Thomson is the name you can trust for high-quality, innovation, on-time delivery, controlled costs and reduced risk regardless of your industry. With extensive experience in numerous industries, including mobile off-highway, medical and health, packaging, food processing, material handling, factory automation, clean energy, and machine tools, Thomson offers the widest selection of linear motion components designed to work together to provide the optimal solution for your specific application.



► [www.thomsonlinear.com/moh](http://www.thomsonlinear.com/moh)

### Mobile Off-Highway

Thousands of actuators – many of them customized – are delivered each year by Thomson to manufacturers of combines, tractors, bulldozers, trains and other vehicles.



► [www.thomsonlinear.com/packaging](http://www.thomsonlinear.com/packaging)

### Packaging

Packaging is a demanding market where Thomson can offer unique products that will improve quality and productivity while lowering manufacturing costs.



► [www.thomsonlinear.com/automation](http://www.thomsonlinear.com/automation)

### Factory Automation

Wherever you need to control a linear motion in a production process, Thomson has the broadest range of suitable products on the market.



► [www.thomsonlinear.com/energy](http://www.thomsonlinear.com/energy)

### Clean Energy

The clean energy market is a fast-growing industry to which Thomson has been supplying standard and customized, high-quality products for many years.



# 80 Years of Innovation, Quality and Trust in Motion Technology

**1940**

**1939**  
Thomson Saginaw produces **first aircraft ball screw** for the B-29 Super Fortress



**1945**  
Thomson invents **world's first anti-friction Linear Ball Bushing® Bearing**



**1946**  
**Thomson is officially founded** by John B. Thomson Sr.



**1947**  
**Multiple circuit ball screws** introduced at Saginaw

**1947**  
Significantly **improved linear ball bushing bearing** patented

**1948**  
**Subminiature clutches and brakes** are released

**1950**

**1951**  
**60 Case® LinearRace®** shafts developed as ground inner raceway for Ball Bushing Bearing



**1953**  
**Precision "A" Bearing** invented with better ball circulation manufacture

**1955**  
**First re-circulating ball screw** introduced on 1955 Chevy



**1955**  
Thomson develops **thread rolling process for ball screws**

**1960**

**1960**  
**Ball screws** are introduced into machine tools

**1962**  
**RoundWay® bearing** patented, offering 20 times greater load capacity than Ball Bushing Bearings



**1965**  
Thomson **Performance Pak** electromechanical actuators are developed

**1967**  
The first generation of actuators **for use in garden tractors and farm equipment** is released



**1970**

**1970**  
**Stainless steel rolled lead screws** and **Supernut®** introduced



**1974**  
**First line of actuators** with parallel motors and both acme and ball screw drives is released

**1974**  
**Self-aligning twin pillow block** is invented

**1969**  
Thomson invents the self-aligning **Super Ball Bushing Bearing**, which provides up to 27 times more life and up to three times greater load capacity than conventional Ball Bushings



**1980**

1990

**1980**  
Anti-backlash  
**Supernut**  
products such as the SNAB, ASAB, TSAB and TAB launched



**1981**  
First **Wiesel linear motion system** presented at Fameta show in Stuttgart



**1981**  
Extra-rigid, 10 times more accurate **XR Ball Bushing Bearing** patented



**1982**  
**Electrak® line actuators** are released for OEMs

**1987**  
**Electrak 205** and the first line of **MCS controls** are released

**1989**  
Production starts on **first high-volume ABS IV ball screw** at 40,000 units/day

2000

**1993**  
Super Smart Ball Bushing Bearing is invented – **216 times the life and six times the load capacity** of a conventional bearing



**1995**  
**Lightweight titanium screw** developed for space flight

**1996**  
**Nyliner® and FluoroNyliner Bushing Bearings** are introduced



**1997**  
**Movopart® 2nd generation linear motion systems** released



**1998**  
The **XC advanced anti-backlash nut** with **ActiveCAM®** is released



**2000**  
The first **LM80 rodless actuator** is released

2010

**2004**  
**Gen IV wipers** developed for harshest environmental conditions

**2004**  
**500 Series** introduced



**2004**  
**MLSM and MLSH** product line released



**2004**  
**T Series** precision linear actuators released



**2010**  
**400 Series linear guide** introduced



**2013**  
**Glide Screw™**, a combined lead screw and guide, is invented



**2013**  
**Electrak Throttle** released



**2013**  
**Max Jac** heavy duty actuator released

**2014**  
**PC Series** precision linear actuators released



**2014**  
**Motorized lead screws** released



**2014**  
**LC Series lifting columns** released



**2016**  
**Electrak HD** electric linear actuator released



**2018**  
**RediMount** motor mounting system released on linear motion systems and precision linear actuators product lines



2020

**2020**  
**Electrak MD** electric linear actuator is released



**2020**  
**H-Track electro-hydraulic linear actuator** is introduced



**2021**  
**The Electrak LL** is launched



**2023**  
**The Electrak XD** is launched, marking a new evolution in electric actuators



**2023**  
**Compact Linear Systems** released



Contact us or any of our 2000+ global distribution partners by scanning the code below  
or visiting [www.thomsonlinear.com/contact](http://www.thomsonlinear.com/contact)



**RegalRexnord™**

[www.regalrexnord.com](http://www.regalrexnord.com)

[www.thomsonlinear.com](http://www.thomsonlinear.com)

Linear\_Motion\_Solutions\_CPEN-0006-04 | 20260220KB | MCB-12419-TL-EN-US 02/26  
Specifications are subject to change without notice. It is the responsibility of the product user to determine  
the suitability of this product for a specific application. All trademarks property of their respective owners.  
©2026 Thomson Industries, Inc. | 2400 Curtiss Street, Downers Grove, IL 60515 USA

**THOMSON®**